

Fracture and Tearing in Oriented Polyethylene

G. E. ANDERTON, L. R. G. TRELOAR

Department of Polymer and Fibre Science University of Manchester Institute of Science and Technology.

Measurements of energy for crack propagation (fracture surface energy) have been made on low-density and high-density polythenes both in the undrawn state and in different states of orientation produced by drawing under various conditions. Both cleavage and tear tests were employed. For the unoriented materials the values of fracture surface energies were in the range 10^4 to 10^5 J m⁻². With increasing orientation (represented by birefringence) the energy for crack propagation parallel to the direction of orientation fell by a factor of approximately 100. The differences between the low-density and high-density polymers, and between the different types of low-density polymers examined, were comparatively slight.

Measurements of crack tip diameter showed a direct relation between this quantity and fracture surface energy. From their comparable studies of the tearing of rubbers Rivlin and Thomas have interpreted such a relationship as implying that the high values of fracture surface energy arise from the work required to deform the material in the crack tip up to the point of rupture. On this basis the reduction in fracture surface energy with increase in orientation is a direct result of the reduction in the diameter of the crack tip.

1. Introduction

The mechanical anisotropy of drawn polymers is well known, and a number of studies have been concerned with the measurement of the elastic constants required to characterise their elastic behaviour in the small-strain region, notably by Raumann and Saunders [1], Raumann [2], Ward [3], Pinnock and Ward [4], Hadley, Ward and Ward [5], Gupta and Ward [6], and Wright [7]. The effects of anisotropy on the yield behaviour of crystalline polymers has also been extensively studied by Ward and his associates [8]. Comparatively little work has been carried out, however, on the anisotropic fracture properties of oriented polymers. For drawn glassy polymers Broutman and McGarry [9], using a cleavage technique, found the energy for crack propagation, or fracture surface energy, for cleavage in a direction parallel to the draw direction, to decrease with increasing orientation. A similar conclusion was arrived at by Curtis [10], who also compared the tensile and impact strengths in the longitudinal and transverse directions, for different degrees of orientation. No comparable

work on the fracture properties of crystalline polymers appears to have been carried out.

The subject is of interest for two reasons. Firstly, drawn crystalline polymers are more highly anisotropic in elastic properties than drawn glassy polymers, and hence might be expected to be more highly anisotropic also in their fracture properties, as the present work will indeed confirm. Secondly, from the practical standpoint, interest is developing in the production of fibres from drawn polymer films by fibrillation processes, so that fundamental methods of studying the phenomena of fracture in these materials may be of value.

It was originally hoped to make measurements of the fracture surface energy for crack propagation in directions both parallel and perpendicular to the direction of orientation. However, it was not found possible to propagate a crack in the transverse direction, so the results are limited to the measurement of the fracture surface energy for crack propagation in the longitudinal direction, for various degrees of orientation. (The same difficulty was encountered by Curtis in the case

of glassy polymers.) Difficulties were also experienced in applying the cleavage test method to samples of low (or zero) orientation. (See 6.4.) For this reason the main emphasis was placed on tearing tests of the type successfully applied by Rivlin and Thomas [14] to rubbers.

2. Formulation of Griffith Theory

In common with most other workers in the field, we shall take as our starting point the Griffith [11] theory, originally proposed in relation to brittle elastic solids of the glassy type. On this theory a crack will propagate only if the accompanying change in the total free energy of the system is negative (or zero). This leads to the criterion for crack propagation,

$$(\partial W/\partial c)_l = -\gamma(\partial A/\partial c) = -2\gamma t \quad (1)$$

where W is the elastically-stored energy in the specimen at the length l , $(\partial A/\partial c)$ is the increase in free surface area due to an extension of the crack by a distance ∂c , t is the thickness of the specimen and γ is the surface free energy (per unit area). In the case of inorganic glasses the value of γ is of the order of 1.0 J m^{-2} (10^3 erg cm^{-2}), and may be regarded as a pure surface free energy such as would arise from the simple separation of two adjacent planes of atoms. Experiments on glassy polymers yield values γ in the range 10^2 to 10^3 J m^{-2} (Berry [12, 13] while for rubbers [14] the values of γ obtained from tear tests (in which γ is equivalent to half the tearing energy T as defined by Rivlin and Thomas) are in the region 10^3 to 10^4 J m^{-2} . In the case of brittle polymers the high values of γ are interpreted as arising from some form of irreversible or plastic deformation of the structure in the region of high stress concentration around the tip of the advancing crack (Berry [15]). In the case of rubbers the still higher values of γ have been shown to be quantitatively equal to the energy required to produce the high extension of the material in the crack tip; as the crack is propagated this energy is dissipated (Thomas [16]).

The application of the Griffith theory in a situation which does not satisfy the original postulates of this theory, namely perfect elasticity or thermodynamic reversibility, is usually justified on the grounds that the formalism remains valid so long as the strain energy in the specimen is uniquely determined by the stress (i.e. that the specimen as a whole behaves elastically) and the irreversible deformation is confined to a small region in the neighbourhood of the crack tip. This argument may be accepted,

provided, of course, that the quantity γ , which is no longer a classical surface free energy, is re-interpreted as a fracture surface energy arising from plastic, viscoelastic or other types of irreversible process, depending on the material examined.

In thermodynamic terms the concept of minimum free energy implies that under conditions of controlled crack growth, as in the cleavage test, the equilibrium crack length can be approached from either side, so that a reduction of the applied force should cause crack closure. It is doubtful whether the process of bond rupture could be considered to be reversible even in the case of an idealised brittle solid; in real materials it almost certainly is not. In this sense the application of the Griffith theory to materials in which rupture is preceded by extensive irreversible processes may be regarded as no different in principle from its application to a classical elastic solid. However it is not difficult to formulate the Griffith theory so as to avoid the implication of reversibility in the actual fracture process. Such a formulation is given below, and applied to the cleavage and tear types of test.

3. Cleavage Test

Consider a double cantilever beam test-piece of the type shown in fig. 1, and let f be the force to

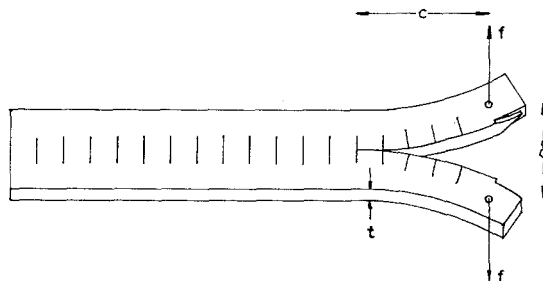

Figure 1 Cleavage test-piece.

produce a separation δ for a particular crack length c . The work done in a further separation $d\delta$ corresponding to an increase in crack length dc is $f d\delta$. We may therefore write

$$f d\delta = \gamma dA + dW = 2\gamma t dc + dW \quad (2)$$

This equation expresses the work as the sum of two terms, of which the first, γdA , is the work required to form the new surface, and the second, dW , the additional work associated with the deformation of the specimen. It will be assumed that the deformation of the specimen, except in

the immediate vicinity of the crack tip, is purely elastic, in which case dW is the increase in the elastically stored energy, or strain energy, in the specimen. For this we may write

$$dW = (\partial W/\partial \delta)_c d\delta + (\partial W/\partial c)_\delta dc \quad (3)$$

Combination of equations 2 and 3 gives

$$[f - (\partial W/\partial \delta)_c] d\delta = [2\gamma t + (\partial W/\partial c)_\delta] dc \quad (4)$$

Now in an increment $d\delta$ at constant c the change in stored energy is equal to the work done by the applied force, namely $f d\delta$, hence

$$f - (\partial W/\partial \delta)_c \equiv 0 \quad (5)$$

It follows that

$$(\partial W/\partial c)_\delta = -2\gamma t \quad (6)$$

which is the Griffith criterion [1].

This formulation makes it clear that the Griffith criterion is applicable whether or not the actual fracture process is reversible.

The development from equation 6 follows the usual lines (Berry [17]). For a double cantilever system in which the individual beams have a moment of inertia of cross-section I

$$f = 3 EI \delta/2c^3; \quad W = 3 EI \delta^2/4c^3;$$

where E is Young's modulus. Hence

$$(\partial W/\partial c)_\delta = (9/4) EI \delta^2/c^4 = -3f\delta/2c \quad (7)$$

Insertion in equation 6 yields

$$\gamma = 3f\delta/4ct \quad (8)$$

In previous work on glassy polymers (Berry [17], Broutman and McGarry [9], Curtis [10]) it has been found that f is not strictly proportional to $1/c^3$. To accommodate this discrepancy c^3 has been replaced by c^n in the first of equations 7, giving the result

$$\gamma = nf\delta/4ct \quad (9)$$

in which n is determined from a plot of $\log(f/\delta)$ versus $\log c$.

There is evidence (Gillis and Gilman [18]) that the deviations from classical beam theory may be attributed to an inadequate treatment of the conditions at the fixed end of the beam; in the present context, however, we are concerned only with the form of the function W , regardless of its interpretation.

4. Tear Tests

Rivlin and Thomas [14] have applied equation 1 to tear tests, using (i) centre crack, (ii) edge-crack and (iii) "trouser-leg" specimens (See fig. 2). For each of these types of test-piece they obtained W by integration of the force-extension

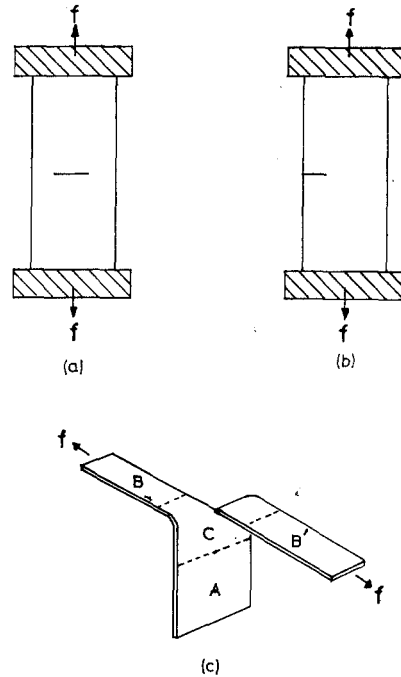

Figure 2 Types of tear test. (i) Centre-crack, (ii) Edge-crack, (iii) Trouser-leg.

curve, for specimens containing initial cuts of various lengths c . By plotting W , for a fixed length l , against c , they were then able to obtain $(\partial W/\partial c)_l$, and hence γ .

This method has the disadvantage of requiring a large number of specimens, but for the trouser-leg type of specimen (fig. 2c) they used a simpler method of analysis, which can be applied to data obtained on a single specimen. The following treatment is equivalent to their analysis, but avoids the direct use of the Griffith criterion.

In place of equation 2 we write

$$f dl = 2\gamma t dc + dW \quad (10)$$

where l is the distance between the points of application of the force f , and W is the elastic strain energy. This type of test-piece may be divided into three regions, an unstrained region A, a region B, B', in which the two legs are in a state of uniform strain corresponding to an extension ratio λ , and a region C, which includes the crack tip, which is in a state of inhomogeneous strain. An increase in the crack length at constant applied force by an amount dc (measured in the unstrained state) transfers a volume of material $A_0 dc$ (where A_0 is the cross-sectional area of the uncut specimen) from the region A to

the region B B', without changing the volume of material in the inhomogeneously strained region C. Hence

$$dW = W_\lambda A_0 dc \quad (11)$$

where W_λ is the stored energy per unit volume corresponding to an extension ratio λ . The increase in length dI being $2\lambda dc$, equation 10 gives

$$f \cdot 2\lambda dc = 2\gamma t dc + W_\lambda A_0 dc \quad (12)$$

which leads to the result

$$\gamma = \lambda f/t - W_\lambda A_0/2t \quad (13)$$

This equation gives γ in terms of the measured force f to produce tearing, the measured extension ratio in the region B B', and the stored energy function W_λ , which is obtainable from the force-extension curve for a single uncut specimen in simple extension.

Equation 13 is equivalent to the result derived by Rivlin and Thomas [14] by application of the Griffith criterion [1], namely (in present notation)

$$-(\partial W/\partial c)_t = 2\lambda f - W_\lambda A_0 \quad (14)$$

The derivation given above does not involve the Griffith criterion directly; it does, however, require that the material shall be perfectly elastic. At first sight it might appear that equation 13 should be applicable to an imperfectly elastic or inelastic material, provided that the function W_λ were replaced by a corresponding function representing the work required to deform the material in simple extension. This reasoning however, is not valid, because it ignores the energy required to deform the material in the inhomogeneously strained middle region C. It is only when the energy in this region is elastically recoverable that its contribution to dW in equation (10) can be ignored.

Nevertheless, there is an important special case in which equation 13 can be applied even when the material is imperfectly elastic or inelastic. This is when the strain in the region B B' is so small that the term $W_\lambda A_0/2t$ is negligible compared with $\lambda f/t$, a condition which can usually be achieved by increasing the width of the specimen (f being approximately independent of the width). Under these conditions, since $\lambda \approx 1$, equation 13 reduces to

$$\gamma \approx f/t \quad (15)$$

This very simple result expresses the fact that, since no significant amount of energy is stored in the bulk of the specimen, the whole of the work performed by the force is consumed in the tearing process, i.e. in the deformation of the material in

the vicinity of the crack tip, and in the formation of the new surfaces.

The use of equation 15 also implies that the strain energy in the middle region C is negligible. Since the tensile stress in this region will normally be less than that in the region B B', this condition will be automatically fulfilled if the strain energy in B B' is itself negligible, provided that there is no significant contribution arising from the bending energy in the two legs. The last condition can easily be satisfied by the use of a sufficiently thin specimen.

Equation 15 is applicable to the present work since for polyethylene sheet of the dimensions used the error introduced in this approximation is less than 3% for both oriented and unoriented material.

5. Materials

Three grades of low-density polyethylene and one grade of high-density polyethylene were used in the present work. The densities and melt indexes as supplied by the manufacturers are listed in table 1.

TABLE 1 Densities and melt indexes of polyethylenes

| Polyethylene | Density | Melt Index |
|--------------|---------|------------|
| LDPE 1 | 0.926 | 0.45 |
| LDPE 2 | 0.918 | 0.23 |
| LDPE 3 | 0.9245 | 0.9 |
| HDPE 1 | 0.96 | 5.0 |

The melt index is here expressed in grammes per 10 min at 190°C in the standard grades. The polymers LDPE 1, LDPE 2 and LDPE 3 were supplied by Monsanto Chemicals Limited, and HDPE 1 was manufactured by British Hydrocarbon Chemicals Limited, and supplied by Monsanto Chemicals Limited.

The first two polymers in table 1 had similar number-average molecular weights, but differed in molecular-weight distribution and were also reported by the manufacturers to show important differences in processing behaviour. Gel permeation data showed that polymer LDPE 1 had a narrow M.W. distribution, while the polymer LDPE 2 had a wide distribution, $\bar{M}_w/\bar{M}_n = 12.53$, these figures being obtained by the manufacturers by gel permeation chromatography. The processing behaviour indicated that LDPE 1 showed a low "die swell" on extrusion (small elastic recovery) while LDPE 2 showed a high "die swell". It was desirable to see

whether these differences could be associated with measurable differences in fracture properties in the oriented state.

The polymer LDPE 3 was similar to LDPE 1 in density, but differed from LDPE 1 in having a higher "die swell" and in being susceptible to environmental stress cracking.

The polymer HDPE 1, which is in a different class, was chosen as representative of a high-density polyethylene. These materials have markedly different physical properties (e.g. modulus) from the low-density polyethylenes.

6. Cleavage Tests

6.1. Preparation of Drawn Specimens

It was considered very important that the original sheets before drawing should be as nearly as possible identical. In order to achieve this the sheets after moulding were given an additional annealing treatment, both these processes being carried out in accordance with the procedure described by Birks and Rudin [19]. The temperature of moulding was 150°C. The annealing involved heating for 1 h at 145°C followed by slow cooling.

Sheets of dimensions 200 × 180 × 6.35 mm were prepared in this way. The thickness of the sheet had to be sufficient to give the required rigidity to the specimens to enable the cleavage test to be performed satisfactorily. The drawing operation was carried out by extending specimens at a constant rate of strain of 40% per min in a specially constructed heated chamber to a predetermined length (draw ratio about 4.0) and subsequently cooling in the extended state. To obtain a series of specimens of different degrees of orientation the temperature at which the drawing operation was carried out was varied (between 50 and 95°C) but the remaining variables – rate of extension and total extension – were maintained constant throughout.

The force required to draw sheets of the required thickness was very high even at elevated temperatures and difficulty was experienced in clamping them in such a way that no slippage occurred. A special type of jaw was designed, the special feature of which was that it provided a restraining pressure on the lateral surfaces in the region of the shoulder of the dumb-bell shaped specimens which were used. This was achieved by the method indicated in fig. 3. A packing plate C was fitted above the polymer to prevent buckling, which could lead to pulling out from the clamps. These clamps

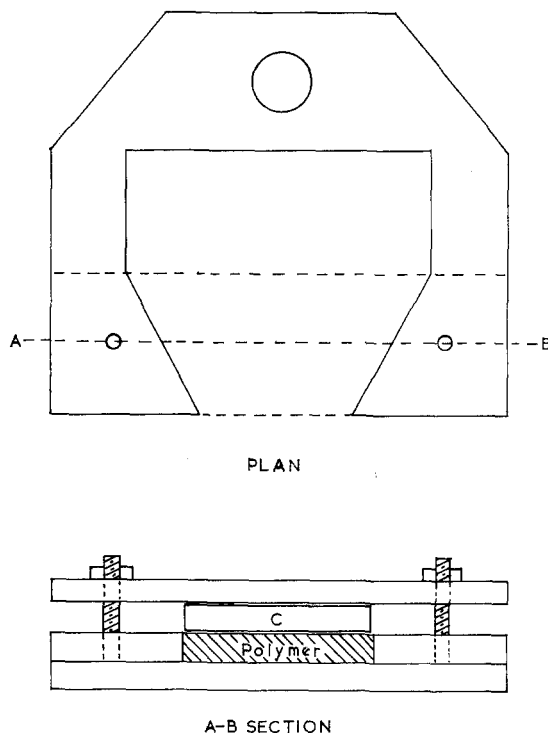

Figure 3 Clamps used for drawing of sheet.

proved to be effective in eliminating slippage during drawing.

6.2. Measurement of Birefringence of Oriented Specimens

There is no unique method of characterising the state of molecular orientation of the drawn polymer, but measurements of birefringence, i.e. the difference of refractive indices in the longitudinal and transverse directions, may be used as a somewhat arbitrary standard of reference. However, the measurement of birefringence, which was carried out by means of a Babinet compensator, presented difficulties because the samples, as drawn, were not sufficiently transparent for direct observations. Measurements were therefore made on thin films or sections cut from the specimens by means of a microtome. For this purpose a small square (of about 5 mm side) of the drawn sheet was mounted on a steel rod, using Araldite as adhesive, and microtomed to give a number of sections of various thicknesses.

Samples of unoriented polyethylene, used as a check, showed that some birefringence was introduced into the specimen by the cutting process. Measurements carried out on sections of

different thickness showed the optical path difference for these samples to be independent of their thickness, indicating that the orientation introduced in the cutting process was confined to a thin surface layer. To allow for this effect, in the case of oriented specimens, the value of optical path difference for the microtomed sections was plotted against their thickness, and the birefringence calculated from the slope of the resultant line. The spurious path difference introduced in microtoming was between 10 and 25% of the total path difference, depending on the orientation.

6.3. Method of Testing

The type of test-piece and the method of testing were essentially the same as in the experiments of Curtis [10] on oriented glassy polymers. The dimensions of the specimen were 140×14 mm. No longitudinal slotting was necessary to control the direction of crack growth.

Owing to the relative thinness of the specimen (about 3 mm after drawing) difficulties were encountered due to the tendency of the two cantilever sections of the specimen to buckle or rotate out of their original plane. This was overcome by the form of mounting shown in fig. 4, which consisted of two U-shaped chan-

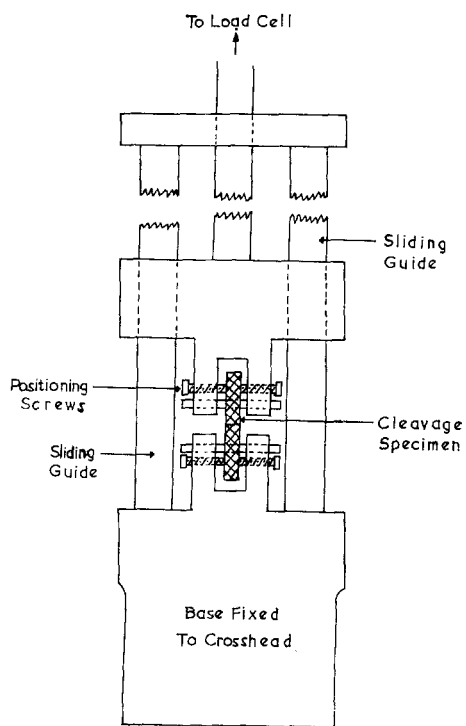

Figure 4 Clamp attachments for cleavage test.

nelled sections maintained in the vertical plane by sliding guides.

A crosshead speed of 5 mm/min and chart speed of 300 mm/min were used in all tests. During the test the position of the tip of the advancing crack was followed by eye, and pips were recorded on the chart as it passed each of the calibration marks on the specimen (fig. 1). From this the value of c , the crack length, was obtained as a function of the applied force f and the separation δ of the ends of the beam.

The calculation of the fracture surface energy γ was carried out by the method described in section 3. The values of the exponent n in equation 9 were in the range 2.4 to 2.98.

6.4. Results

The results of these experiments are shown in fig. 5. As can be seen the results are limited to a

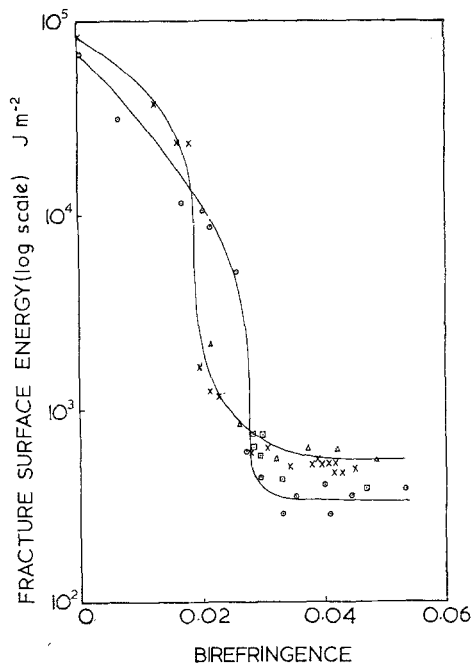

Figure 5 Fracture surface energy versus birefringence for low-density polyethylenes from cleavage and tear tests. LDPE 1, Δ cleavage, \times tear tests. LDPE 2, \square cleavage, \circ tear tests.

range of birefringence between 21×10^{-3} and 48×10^{-3} . This was because it was found impossible to obtain any values of γ below a birefringence of 21×10^{-3} even when the specimens were slotted along their centre lines to control the direction of crack growth. At these low orient-

ations, fibres were pulled out from the main body of the polymer and across the crack tip, so that no meaningful measurements could be made.

7. Tear Tests

As mentioned above, studies by Rivlin and Thomas [14] of both edge- and centre-crack tensile specimens made use of a series of specimens containing initial incisions of different length. Attempts to apply the edge-crack technique to specimens of polyethylene containing edge cracks cut with a razor blade did not yield consistent and meaningful results. Examination of the specimen during the course of the test showed progressive enlargement of the radius of the crack tip with increasing extension, accompanied by considerable "drawing" of the whole section of the specimen in the region of reduced cross-sectional area. These effects were present for all degrees of orientation, but were most marked in the case of the unoriented material.

Under these conditions it is apparent that the physical state, and hence the physical properties, of the material in the section of reduced area were being modified in the process of testing, the extent of this modification being a function of the geometry of the particular specimen (length of crack, etc.). Such changes in material properties destroy the basis for the application of the Griffith theory, which assumes, among other things, that the material properties are not changed in the course of testing (except possibly for a small region in the neighbourhood of the crack tip, in which case any changes can be considered to be the same for all specimens).

Because of these difficulties, the edge-crack type of test was abandoned in favour of the "trouser-leg" test. This differs fundamentally from the edge- or centre-crack types of test in that the stress-bearing region is limited to the immediate vicinity of the tip of the crack and does not extend across the whole specimen.

7.1. Preparation of Samples

Thin sheets (~ 0.6 mm) of polyethylenes LDPE 1, LDPE 2 and LDPE 3 were prepared by the method described in section 6.1.

To produce specimens of low orientation (which could be satisfactorily examined by a tear test but not by cleavage), a somewhat different procedure from that used for the cleavage samples was used. Strips of width 20 mm were cut from the annealed sheet and were

drawn in the standard heated chamber of the Instron testing machine at a rate of 40% per min, based on the original length. The temperature was held constant (at 90°C), different degrees of orientation (birefringence) being obtained by varying the final extension. The polymers could be drawn without necking up to a draw ratio of about 2.5 (birefringence $\sim 35 \times 10^{-3}$). In order to obtain a higher birefringence the polymer was fully drawn, i.e. to a draw ratio of about 4.0, the necked region extending over the whole length of the specimen. Still higher birefringences were obtained by reducing the drawing temperature. In this way the range of birefringence was extended up to about 50×10^{-3} . After drawing, all the samples were cooled in the extended state. For these thinner sheets microtoming was not necessary, the transparency being sufficient to enable direct measurements of optical path difference to be made.

7.2. Method of Testing

The test-pieces used were of rectangular shape, their length being not less than 50 mm and their width about 10 mm (depending on the final draw ratio). An initial cut of length about 20 mm was inserted along the centre line of the specimen parallel to the length direction by means of a razor blade whose edge was held perpendicular to the plane of the strip and inserted from the end, i.e. in the direction in which the crack was to be propagated, thus giving a sharp tip to the initial crack. The two free ends thus formed were clamped in the Instron jaws to give a test-piece of the form shown in fig. 2(c). The jaws were then separated at a rate of 5 mm/min and the force-elongation curves were recorded.

7.3. Results

The tearing curves obtained were of two distinct types. Fig. 6 shows the curve for a sample of LDPE 3 of birefringence 38.8×10^{-3} , which was typical of *all* oriented samples. Fig. 7 shows the curve for a sample of undrawn LDPE 3 which was typical of all unoriented samples.

For the oriented polymers the force at first increased to a high value then dropped and oscillated about a constant value. The value of γ was calculated from equation 15, using the final mean value of f .

The high initial force is presumably required to convert the artificial crack to a natural one of smaller radius associated with continuous propagation.

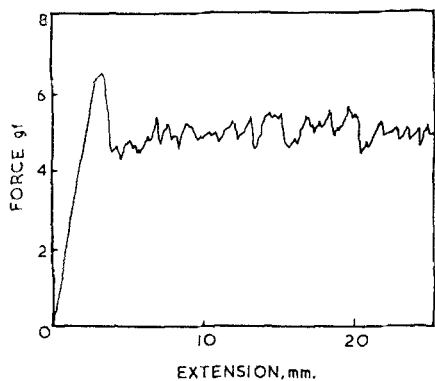

Figure 6 Tearing curve for LDPE 3 of birefringence 0.0388 and thickness 0.14 mm.

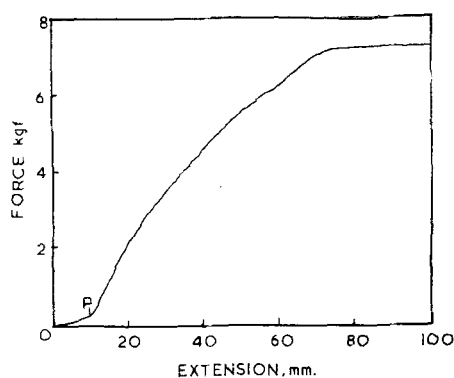

Figure 7 Tearing curve for undrawn LDPE 3 of thickness 0.92 mm.

For the unoriented polymer the curve was very different. Tearing started at the point P indicated in fig. 7, but as tearing proceeded the force rose continuously until it ultimately attained a constant value f_c . The value of γ was again calculated from equation 15 using the value of f ($f = f_c$) corresponding to the final steady state.

Fig. 8 shows the tear-test results for all three polymers tested. As can be seen from the curves a rather complex pattern of dependence of γ on birefringence emerges. The slope of the curve is at first rather small. Beyond this region there is a rapid fall with increasing orientation which is then followed by a final levelling off at still higher orientations. From the unoriented to the most highly oriented material the value of γ falls by a factor of the order of 100.

Fig. 5 shows the results of tear tests on LDPE 1 and LDPE 2 compared with the results of cleavage tests on the same polymers. The

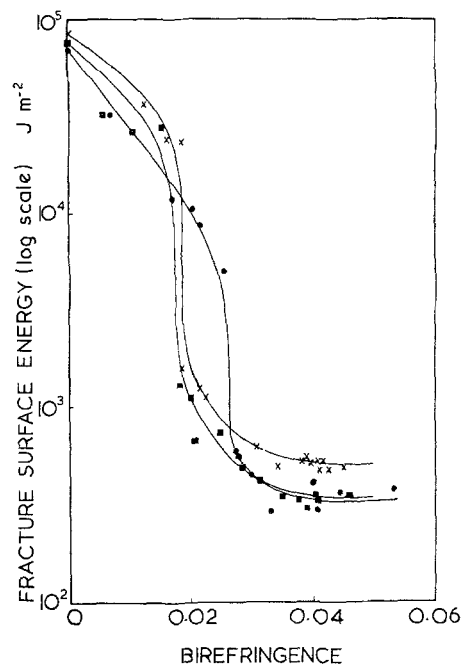

Figure 8 Fracture surface energy versus birefringence from tear tests.

× LDPE 1, ● LDPE 2, ■ LDPE 3.

results of cleavage tests and tear tests appear to be reasonably consistent.

8. Measurement of Crack Tip Radii

The data shown in fig. 8 were calculated on the basis of the steady tearing force f_c derived from curves of the type shown in fig. 7. In using this value of f we have tacitly ignored the very much lower values of f corresponding to the earlier stages of the tearing. We will now consider how these are to be interpreted.

Equation 15 is applicable in principle to any point on the tearing curve. We must therefore conclude that for materials giving this type of curve the corresponding fracture surface energy is not a constant, but increases continuously in the course of the test until steady-state conditions are achieved. The force versus length curve is, in fact, a replica of the γ versus c curve. An explanation of this variation may be sought on the basis of the quantitative interpretation of the tearing energy provided by the work of Thomas [16] on the tearing of rubber. Thomas showed that the values of γ which he obtained could be quantitatively related to the strain energy in the material in the immediate vicinity of the tip of

the tear. Since the amount of material so strained is proportional to the diameter of the tip of the crack, he arrived at the approximate relation

$$2\gamma \approx d E_b \quad (16)$$

where d is the diameter of the crack tip and E_b is the strain energy per unit volume corresponding to a simple extension up to the point of rupture.

The validity of this relationship for polyethylene was investigated by measuring the crack tip diameter. Values of γ were determined for unoriented polyethylene (LDPE 1) sheet of thickness about 1 mm at various points along the force-deformation curve up to the region of constant tearing, using equation 15. The value of E_b , obtained from an experiment on the same material in simple extension, was 0.997 J mm^{-3} . The diameter d was then calculated, for each value of γ , from equation 16. The results are given in table 2, in which f is the force on a specimen of thickness 0.95 mm.

TABLE II Crack tip diameters for unoriented polyethylene

| f , kgf | γ , 10^4 J m^{-2} | d , calc., mm | d , measured mm |
|---------------|------------------------------------|-----------------|-------------------|
| 1.00 | 1.03 | 0.0207 | 0.046 |
| 3.00 | 3.09 | 0.0620 | 0.088 |
| 5.00 | 5.15 | 0.1033 | 0.141 |
| 7.00 | 7.22 | 0.1409 | 0.235 |
| (f_c) 8.5 | 8.75 | 0.1756 | 0.308 |

Direct measurements of the corresponding crack tip diameters were made, by means of an optical microscope fitted with a filar eyepiece, on specimens removed from the testing machine at the values of load indicated. Difficulty was encountered in distinguishing the crack tip, especially at large values of the force, since the material near the crack tip was highly distorted. Values of diameter for different specimens at any particular value of f showed an average deviation from the mean of about 7%. Bearing in mind that the crack tip radius required by the theory is that corresponding to the undistorted state, and would therefore be somewhat less than the final strained radius, the results shown in table 2 suggest very strongly that in polyethylene, as in rubber, the high value of γ is associated with the energy required to deform the material in the crack tip.

Crack tip diameters were also measured for oriented samples of LDPE 3. The results are shown in table 3.

TABLE III Crack tip diameters for oriented polyethylene

| Birefringence, 10^{-3} | γ , 10^3 J/m^2 | d , measured, mm |
|--------------------------|---------------------------------|--------------------|
| 10.3 | 26.3 | 0.0494 |
| 19.95 | 1.12 | 0.00267 |
| 37.5 | 0.333 | 0.00044 |

The last two measurements of diameter were obtained using a scanning electron microscope. No direct comparison with equation 16 was possible since it was not found possible to obtain satisfactory values for E_b : when the polyethylene was strained transversely to the orientation direction it was found impossible to produce drawing in this direction and the material failed prematurely at the clamps. The results do however show that, as in the case of unoriented polyethylene, as the surface energy decreases the crack tip diameter also decreases. This implies that the value of γ is dependent on the diameter of the crack tip and that the large reduction of γ on orientation is due essentially to a reduction in crack tip diameter.

9. High-density Polyethylene (HDPE 1)

With this material the previously described annealing procedure yielded sheets which proved very difficult to draw satisfactorily. Polymer sheet which had simply been pressed from chip at a temperature of 165°C and not annealed in any way, however, gave satisfactory drawing. This type of sheet was therefore used for the experiments although the possible effect of the different annealing procedure on the results is not known. The drawing was carried out between 50 and 100°C . Low values of birefringence could not be obtained because of necking of the samples at even small draw ratios which resulted in high orientation in the necked regions. The alternative method of reducing orientation by increasing the drawing temperature also failed because fracture occurred during drawing at temperatures greater than 100°C .

The value of γ for the unoriented material was found to be $3.86 \times 10^4 \text{ J m}^{-2}$. Between birefringences of 30×10^{-3} and 60×10^{-3} (the range over which suitable samples could be produced) the value of γ was almost constant at $7.12 \times 10^3 \text{ J m}^{-2}$. Comparing these figures with those for low-density polyethylene (fig. 8) it is seen that the high-density material has a somewhat lower value of γ in the unoriented state, but that the reduction on orientation is rather less marked. These differences are however, surpris-

ingly small, in view of the large differences in crystallinity and in other physical properties shown by these two types of materials.

10. X-ray Measurements

An attempt was made to obtain further evidence concerning the state of orientation in the variously-oriented samples by the study of their X-ray diffraction patterns. Unlike the birefringence, which is affected by both the crystalline and non-crystalline components of the structure, the X-ray patterns are of course determined essentially by the crystalline component.

The photographs were taken with Cu K_{α} radiation and were analysed by means of a microdensitometer scanning azimuthally along the (110) reflection to determine its intensity at varying angular displacements from the meridian.

Up to a draw ratio of 2.0 ($\Delta n = 18.4 \times 10^{-3}$) at 90°C the (110) reflections showed a split in the intensity peak, which has been shown [7, 11] to imply that the chain axial directions in the crystallites are inclined at a definite angle to the draw direction. For draw ratios corresponding to a birefringence of 18.4×10^{-3} and upwards only a single peak of intensity was observed, indicating alignment of the crystallite axes along the draw direction.

It is found that the orientation at which the rapid fall in γ started, i.e. $\Delta n \approx 20 \times 10^{-3}$ (fig. 5), coincides very closely to the change in the type of orientation of the chain axes. It is tentatively suggested that the rotation of the chain axes into parallelism to the draw direction is responsible for the large drop in the value of γ .

11. Conclusions

The following broad conclusions may be drawn from the work reported in this paper.

(1) The value of the fracture surface energy γ for unoriented polyethylene is of the order 10^4 J m^{-2} . The effect of orientation is to decrease the value of γ for crack propagation parallel to the direction of orientation by a factor of approximately 100.

(2) In the effect of orientation on the value of γ the differences between the three types of low-density polyethylene examined, and between the high-density and low-density materials, were rather slight. No definite relation could be established either with molecular-weight distribu-

tion or with "die-swell" behaviour.

(3) The values of γ for the unoriented polyethylenes are similar to, but somewhat higher than, the values obtained by Rivlin and Thomas for rubbers. This suggests a basic similarity in the mechanism of tearing. The association of γ with the energy required to extend the material in the crack tip to the point of rupture is supported by quantitative evidence on the relation between γ and the diameter of the tip of the crack. The inference is that the reduction of γ on orientation of the polymer is due primarily to a reduction in the diameter of the crack tip.

Acknowledgement

Acknowledgement is made to Monsanto Chemicals Limited for their generous financial support of this work, and to Dr T. T. Jones and Mr S. Baxter, for a number of helpful discussions.

References

1. G. RAUMANN, and D. W. SAUNDERS, *Proc. Phys. Soc.* **77** (1961) 1028.
2. G. RAUMANN, *Proc. Phys. Soc.* **78** (1962) 1271.
3. I. M. WARD, *Proc. Phys. Soc.* **80** (1962) 1176.
4. P. R. PINNOCK, and I. M. WARD, *Brit. J. Appl. Phys.* **15** (1964) 1559.
5. D. W. HADLEY, I. M. WARD, and J. WARD, *Proc. Roy. Soc.* **A285** (1965) 275.
6. V. B. GUPTA, and I. M. WARD, *J. Macromol. Sci.-Phys.* **B2(1)** (1968) 89.
7. H. WRIGHT, Ph.D. Thesis. Manchester, 1968.
8. N. BROWN, R. A. DUCKETT, and I. M. WARD, *Brit. J. Appl. Phys.* **1** (1968) 1369.
9. L. J. BROUTMAN, and F. L. MCGARRY, *J. Appl. Poly. Sci.* **9** (1965) 589.
10. J. W. CURTIS, *J. Phys. D. (Appl. Phys.)* **3** (1970) 1413.
11. A. A. GRIFFITH, *Phil. Trans.* **A221** (1920) 163.
12. J. P. BERRY, *J. Poly. Sci.* **50** (1961) 107.
13. J. P. BERRY, *J. Poly. Sci.* **50** (1961) 313.
14. R. A. RIVLIN, and A. G. THOMAS, *J. Poly. Sci.* **10** (1953) 291.
15. J. P. BERRY, *J. Appl. Poly. Sci.* **33** (1962) 1741.
16. A. G. THOMAS, *J. Poly. Sci.* **18** (1955) 177.
17. J. P. BERRY, *J. Appl. Phys.* **34** (1963) 62.
18. P. P. GILLIS, and J. J. GILMAN, *J. Appl. Phys.* **35** (1964) 647.
19. A. M. BIRKS, and A. RUDIN, *A.S.T.M. Bull.* **63** (Dec. 1959).

Received 14 February and accepted 12 April 1971.